

1. CONTENTS

1. Contents	1
2. Control Location	3
3. Before Riding	4
4. Safe Riding	4
5. Driving	5
6. Use Genuine Spare Parts	5
7. Use of Each Component	6
Gauges	6
Operation of Ignition Switch	8
Use of Buttons	9
Goods Hook	12
Saddle Lock	12
Storage Box	12
Pillion Step	12
Fuel Tank Cap	13
Cup Frame	13
Brake	14
8. Important Points and Cautions for Starting Engine	15
9. The Best Way to Drive off	16
The Control of Throttle Valve Handle	16
Parking Method	16
10. Inspection and Maintenance before Riding	17
Routine Inspection	17
Engine Oil Inspection and Change	17
Fuel Inspection	18
Transmission Oil Inspection and Change	18
Inspection and Adjustment of Brake Free Play	19
Disc Brake Inspection	19
Throttle Valve Handle Clearance Adjustment	20
Inspection and Maintenance of Battery	21
Tire Inspection	22
Steering Handle Front Shock Absorbers Inspection	22
Rear Cushion Hardness Setting	23
Checking and Changing Fuses	23
Checking the Turn Signal Lights and Horn	23

1. CONTENTS

Checking the Front and Rear Lights	24
Checking the Brake Light	24
Checking for Fuel Leakage	24
Checking the Lubrication of Body's Various Mechanisms	24
Checking the Spark Plug	24
Cooling system inspection	25
Replenishment of coolant	25
A reference table for anti-freeze concentration percentages under different temperatures	26
Crankcase Blow-By Ventilation	26
Checking the Air Cleaner	27
Checking The Left Crankcase Cover Air Cleaner	27
11. When there is an Abnormal Condition or a Trouble	28
Diagnosis when Engine does not Start	28
12. C.D.I. Electrical Ignition System	28
13. Suggestions on Engine Fuel	28
14. Transmission Oil	28
15. Cautions for Riding Scooter	29
16. Periodical Maintenance Schedule	30
17. Specification	31

2. CONTROL LOCATION

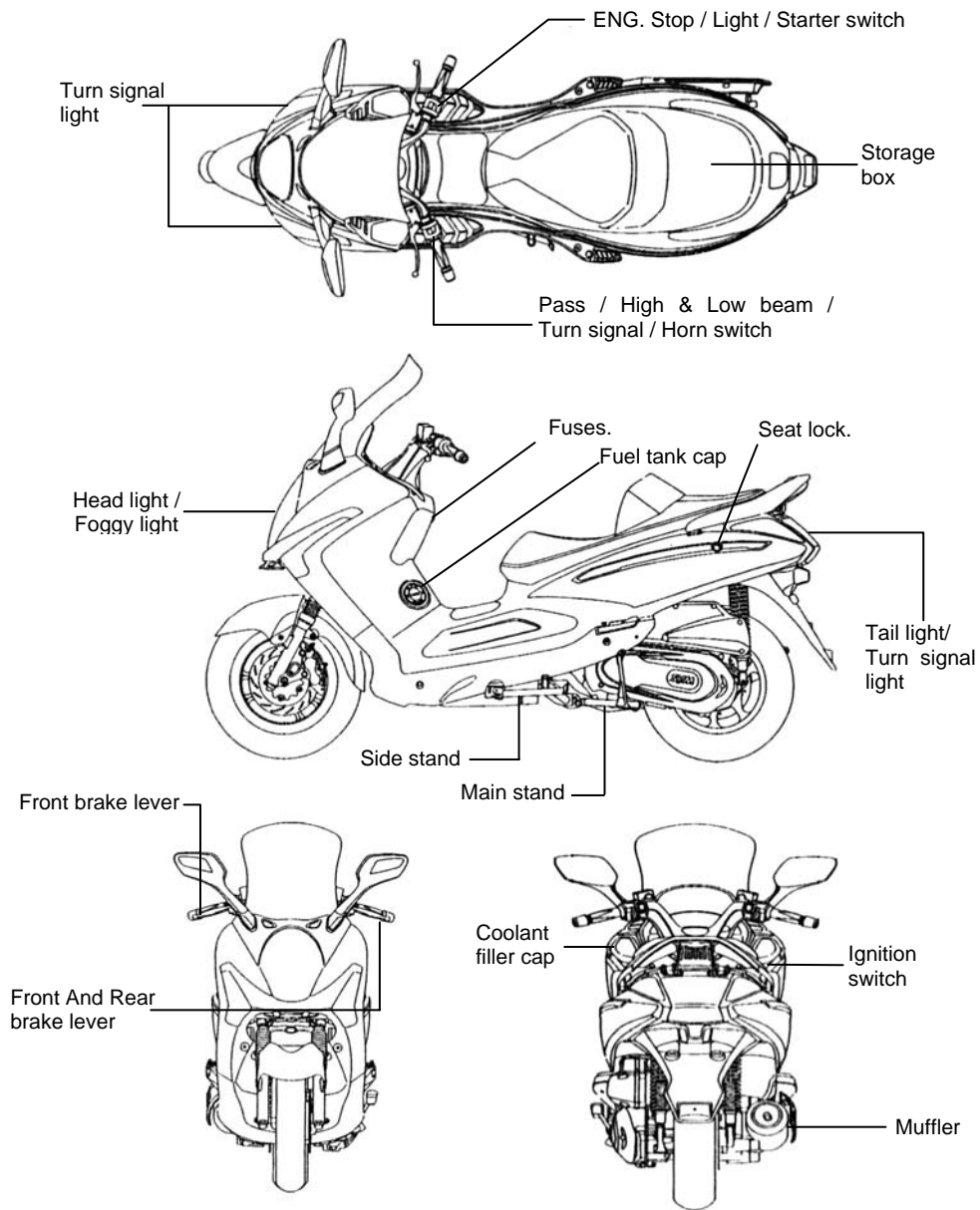

3. BEFORE RIDING

This manual describes the correct usage of this scooter including safety riding, simple inspection methods and so on.

For a more comfortable and safety riding, please read this manual carefully.

For your benefit, please ask your **SANYANG** dealer the operating manual and carefully read the following:

- Correct use of the scooter.
- Pre-delivery inspection and maintenance.

Thank you very much for your patronage

In order to maximize your scooter's performance, a periodical inspection and maintenance should be completely carried out.

We recommend that after riding your new scooter for the first 300 kilometers, you should take your scooter to the original dealer for an initial inspection, and to have your scooter inspected periodically every 1000 kilometers thereafter.

- In case the scooter's specifications and construction are modified and different from the photos and diagrams on the owner's manual / catalogues, the specifications and construction of the actual scooter shall prevail.

4. SAFE RIDING

It is very important to be relax and clothe properly when driving, observe traffic regulations, do not rush, always drive carefully and relaxed.

Usually, most people would ride their newly bought scooter very carefully, but after they became familiar with their scooters, they tended to become reckless which may result in an accident.

To remind you:

- Please wear a safety helmet, and properly tighten the chin belt when riding a scooter.
- Clothes with open or loose cuffs may be blown by wind and cause the cuffs to get caught on the steering handle and thus affects riding safety.
- So, put on clothes with tight sleeves.
- Hold the steering handle by both hands when riding. Never ride with only one hand.
- Observe the speed limit.
- Wear suitable low-heel shoes.
- **Perform periodical maintenance and inspection in accordance with the schedule.**

WARNING!!

- To avoid getting burned by exhaust pipe when taking a passenger. Make sure your passenger has put his/her feet on the pedals.
- After running, the exhaust pipe is very hot, be careful not to get burned when conducting an inspection or maintenance.
- After running, the exhaust pipe is very hot, select a suitable location to park your scooter to avoid others getting burned by the exhaust pipe.

CAUTION:

Modified scooter will affect its structure or performance, and cause poor engine operation or exhaust noise, which will result in shortening the scooter's service life.

Besides, modification is illegal and does not conform to the original design and specifications.

A modified scooter will not be covered by warranty, therefore, do not modify your scooter at will.

5. DRIVING

Keep the related parts of your body such as arms, palms, lumbar, and toes relax and ride with the most comfortable posture in order to be able to react quickly whenever it is necessary.

- Rider's posture will greatly affect riding safety. Always keep your body's gravity in the center of the saddle, if your body's gravity is on the rear part of saddle, the front wheel load will be reduced, and this will cause the steering handle shaking. It is dangerous to ride a scooter with an unstable handle.
- It will be much easier to make a turn if rider inclines his body inward when turning. On the other hand, the rider will feel unstable if his body and the scooter do not incline.
- The scooter is hard to control on a bumpy, unlevelled, unpaved road, try to know the road conditions in advance, slow down and use your shoulder's force to control the handle.
- Suggestion: Do not load objects on the front pedals unnecessarily, to avoid affecting the riding safety and the operation of steering handle.



CAUTION:

The rider's feeling on the handle is slightly different with a load or without a load. Overload may cause the handle to swing and affects the riding safety. Therefore, do not overload your scooter.



CAUTION:

- Do not place flammable materials such as rags between the body side cover and engine to avoid components damaging by fire.
- Do not load objects on areas not specified for loading to avoid damage.

SUGGESTION

To maximize the scooter's performance and prolong its service life:
The first month or first 1000km is the wear- in period for the engine and components.
Avoid rapid acceleration, and keep the speed below 60km/hr.

6. USE GENUINE SPARE PARTS

In order to maintain the scooter's best performance, each part's quality, material, and machined precision must conform with the design requirements. "**SYM Genuine Spare Parts**" were made from the same high quality materials used for the original scooter. No parts would be sold to the market until they could meet the designed specifications through sophisticated engineering and stringent quality control. Therefore, it is necessary to purchase "**SYM Genuine Spare Parts**" from "**SYM Authorized Dealers or Franchised Dealers**" when replacing spare parts. If you buy cheap, or fake substitute parts from the market, no guarantee can be provided either for the quality or durability. Also, it may result in unexpected troubles and lower the scooter's performance.

- Always use **SYM Genuine Spare Parts** to keep your scooters pure blood and to ensure its long service life.

7. USE OF EACH COMPONENT

(The following is SYM 4 stroke liquid cooling scooter's basic operation, and they could vary from different individual models. Please consult the end of this manual.)

Gauges

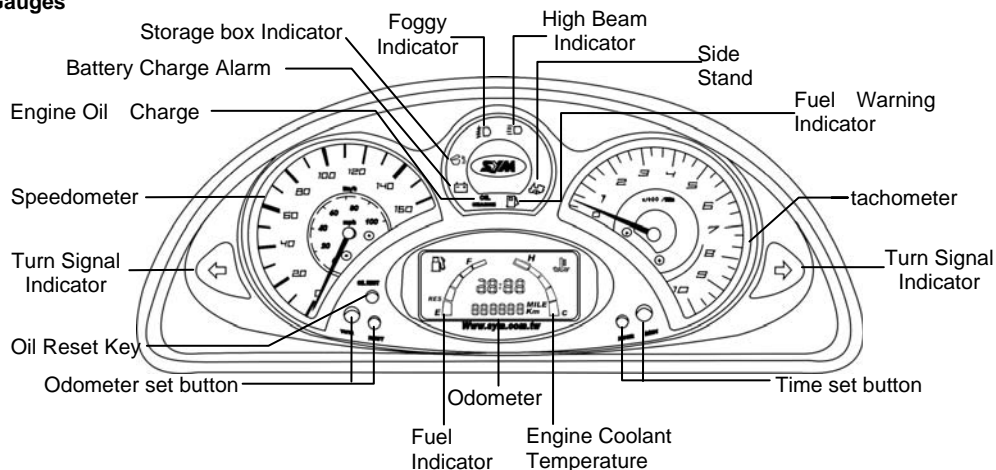

⚠ CAUTION :

- Before battery installation, please do not use the kick starter to start the engine, in prevention
- Not to have trouble on electrical meter working, or damage the electrical meter.
- Do not wipe plastic components, e.g. instrument panel, headlight, with organic solvents such
- As gasoline...etc. to avoid damaging these components.

• INFORMATION OF THE GAUGE BOTTON

1. **O / R** : clear the oil reset.
 2. **T / T** : switch between total kilometer and trip kilometer.
 3. **T / R** : clear the trip kilometer.
 4. **HOUR** : time(hour) setting.
 5. **MIN** : time(minute) setting.
- **High Beam Indicator(blue)** : This indicator comes on with high beam headlight is turned on.
 - **Foggy Indicator(green)** : This demonstrated the fog lamp opens.
 - **Storage box Indicator** : This demonstrated the Storage box lamp opens.
 - **Turn Signal Indicator(green)** : The left or right Indicator will be flashing according to the operated directions of turn signal light switch when it is turned on.

• Fuel Gauge :

The fuel gauge doesn't come on when the main switch is at "OFF" position. When key switch is turned to "ON", and the "pointer" indicates above "E" position, it shows how much fuel in the tank, and also the fuel indicator light keeps coming on. When the "pointer" is below "E" position, the fuel indicator flashes, and the fuel warning indicator(orange) will come on. It means there is only approximately 1.2 liter of fuel left in the tank. Refuel octane 92/95/98 unleaded gasoline immediately.

7. USE OF EACH COMPONENT

- **Odometer :**

This odometer shows the total kilometers this scooter has been driven.

Total kilometer : This shows the total kilometers of this scooter. It shows six digits; 5 in kilometers and 1 in hundred meter. (The total kilometer will return to zero if it runs over 100,000 kilometers.)

Trip kilometer : The rider can measure the trip kilometers. It shows four digits; 3 in kilometers and 1 in hundred meter. (The trip kilometer will return to zero if its measurement is over 1,000 kilometers.)

- **Engine Coolant Temperature**

To indicate engine coolant temperature.

When the main switch turns to "ON", the LCD and the water temperature indicator keeps coming on.

Normally, the LCD indicator should be below the (H) position when the scooter is operating. If the LCD indicator stays above (H) position, the water temperature indicator flashes. Please check the coolant level of spare coolant tank and check cooling fan for proper operation.



CAUTION:

The indicator will stay above (H) position when engine is run under high temperature for a long period of time. In this case, the only way to cool the engine is to stop the engine.

- **Time setting**

Set time in 24 hour mode.

When the main switch turns to "ON" the clock shows hours and minutes in 24 hour mode.

At this "Time mode" press HOUR and MIN bottom at the same time, and enter the "Time setting mode".

At this moment the time digit flashes: press the HOUR bottom once and the hour increases. Keeping on pressing for 2 seconds can accelerate the adjustment. (The minute adjustment by MIN bottom is the same like this.)

At "Time setting mode" press HOUR bottom and this bottom will not flash for 2 seconds. (The same as MIN bottom.)

When time setting completed. Press ALARM bottom or without pressing HOUR or min bottom for 3 seconds to exit "Time setting mode".

7. USE OF EACH COMPONENT

OPERATION OF IGNITION SWITCH

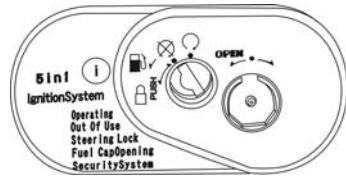

IGNITION SWITCH



IGNITION SWITCH KEY



"Start" position

- Engine can be started in this position.
- Ignition switch key can not be removed.



"Stop" position

- Engine is shut off and can not be started in this position .
- Ignition switch key can be removed.



"Steering handle lock" position

- Turn the steering handle to left and press ignition switch key down and then lightly turn it to left to the "LOCK" position.
- The steering handle is locked in this position.
- Ignition switch key can be removed.
- When unlocking, simply turn the key from "LOCK" to "OFF."



"OPEN" position (fuel tank cap open) :

- How to open : Insert your key into the ignition switch, and turn it to the left.
- How to lock : Push the fuel tank cap and it locks automatically.



CAUTION:

- Never operate the ignition switch key when the scooter is running. To turn the ignition switch to "OFF" and "LOCK," will shut off the electrical system and that may result in a dangerous accident. Therefore, the ignition switch can only be turned off after the scooter has been completely stopped.
- Always remove the key and be sure to take the key away with you after locking the steering handle before leaving your scooter.
- If ignition switch remains in the "ON" position for a prolonged period after the engine has been stopped, the battery's capacity will be reduced and this may affect the engine's start ability.

7. USE OF EACH COMPONENT

USE OF BUTTONS

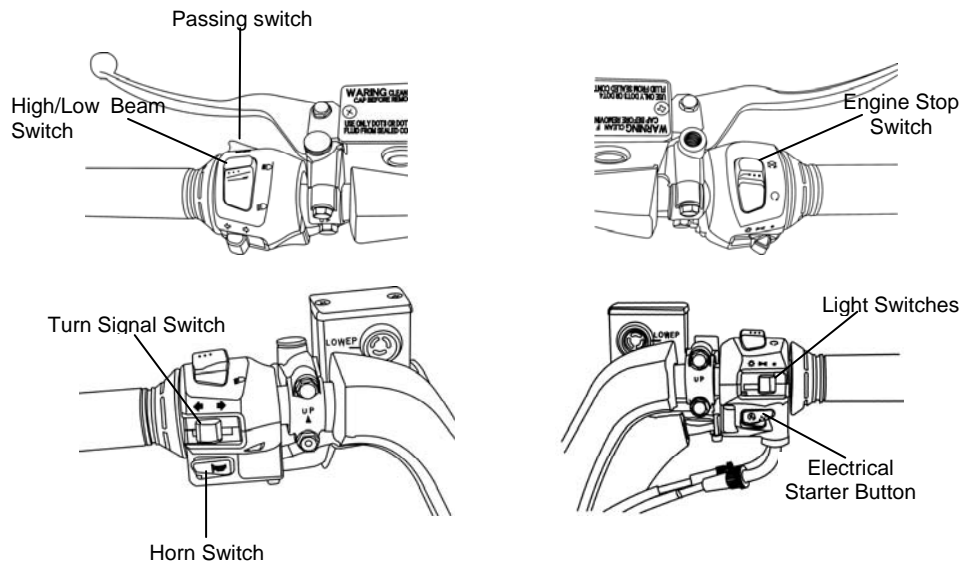

• Light Switches



When the switch is turned to this position as the engine is being started, headlight, rear light, instrument panel light, and position light will come on.

Note:

Position Light Function:

This light can indicate the scooter position when the scooter is running in dim, rainy, or foggy weather.



When the switch is turned to this position as the engine is being started, rear light, instrument panel light, and position light will come on.



When the switch is turned to this position, all lights will go off.

• Engine Stop Switch



Switch to this position to turn off the engine when a state of emergency.



Switch to this position and the engine can be started.

7. USE OF EACH COMPONENT

• Electrical Starter Button



This is a starting motor button (switch) for engine starting.

With the main switch "ON", press this button while holding the front or rear brake lever will start the engine.



CAUTION:

- Release this button immediately after engine has been started, and never press the button again to avoid damaging the engine.
- This mechanism is a safety design. The engine can only be started after the front or rear brake lever (pedal) has been applied.
- Do not use light system. Turn headlight and turn signal lights to the "OFF" position when the engine is being started.

• High/Low Beam Switch

This is the high and low beam of headlight switching switch. Press this switch to switch between high and low beams.



This is for high beam.



This is for low beam. (Please turn to low beam when riding in city)

• Passing Switch



Turn ignition switch "ON" and press this button down. Then, the high beam of headlight will come on immediately to warn the driver of the vehicle ahead that you intend to overtake him/her. (For overtaking, high beam indicator will come on at this time) This button will return to original position after releasing

• Horn Switch



Press this button down when ignition switch is in the "ON" position, the horn will sound.



CAUTION:

Do not press this button when you are in the area where there's no honking.

Hazard Switch



The main switch in the "ON" position, cuts according to this switch, four directions lantern festivals dodge extinguish do move, also can simultaneously dodge on the display board direction indicating lamp extinguishes does moves. If stops the vehicle has when the transportation frequent dangerous position or the vehicle the breakdown, may use the dangerous police to show the switch. The main switch in the "ON" position, hazard switch only then may close.

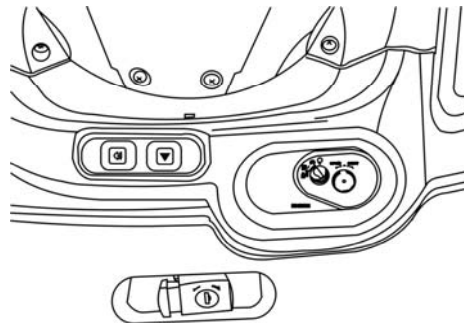

Fog lamp Switch



This is for fog lamp.

7. USE OF EACH COMPONENT

• Turn Signal Switch

Turn signal lights are used when turning left/right or changing lane.

Turn ignition switch to "ON", and slide the turn signal switch to left or right. Then, the turn signal lights will flash.

To release, simply return the turn signal light button to the original position.



Right-side turn signal light flashing means you intend to make a right turn.



Left-side turn signal light flashing means you intend to make a left turn.

• Assist headlight case

The accessory socket is inside the inner box. You can use the accessory socket to power a trouble light, PDA, spotlight, radio, or cell phone, etc.

CAUTION:

- Do not plug in any head-generating accessory such as an automobile cigarette lighter because it can damage the socket.
- Do not use the socket in raining day.
- Do not splash water or other liquid on socket when using the socket.

To use accessory socket, turn the ignition switch ON to start the engine. Then turn the headlights OFF, and open the accessory socket cap.

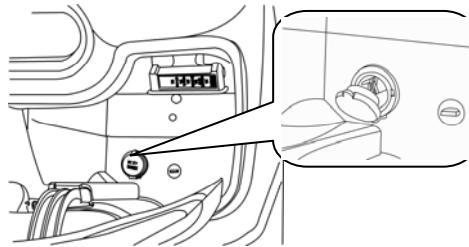

7. USE OF EACH COMPONENT

GOODS HOOK

- Hangs up the goods

SADDLE LOCK

• Unlock:

Insert the ignition switch key and turn to left to unlock.

• Lock:

Press the saddle down and it will be locked automatically.

After the saddle has been locked, check to make sure it has been locked properly by lightly lifting the saddle.

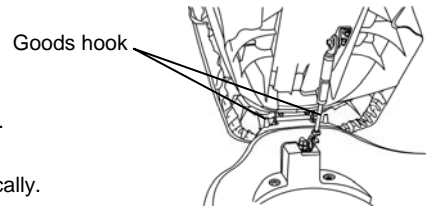

CAUTION:

- Do not put the key inside the storage box after unlocking to avoid the key being locked inside the storage box when the saddle is pressed down automatically.
- Be sure to remove the key after the saddle has been locked.

STORAGE BOX

- This box is located under the saddle.
- Maximum load capacity: 10kg.
- Do not store valuables in the box.
- Make sure that the saddle has been locked completely after it was pressed down.
- Take out valuables before washing to avoid wetting these objects.
- Do not place thermal sensitive objects in the box because of engine's heat and high temperature.

PILLION STEP

- Press down the button and the pillion step goes out.

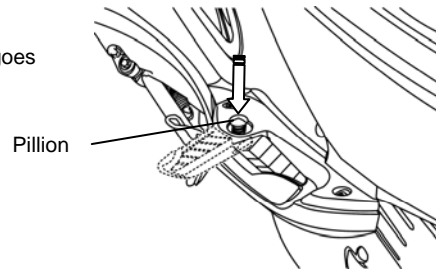

7. USE OF EACH COMPONENT

FUEL TANK CAP 【Fuel refilling】

1. Insert ignition switch key into the ignition switch, and turn the key to the left, then the cap can be removed.
2. Do not fill above the fuel upper limit when refueling.
3. Holds down "PUSH" downward to press, hears to the "CLICK" sound, Fuel tank cap can be locked.

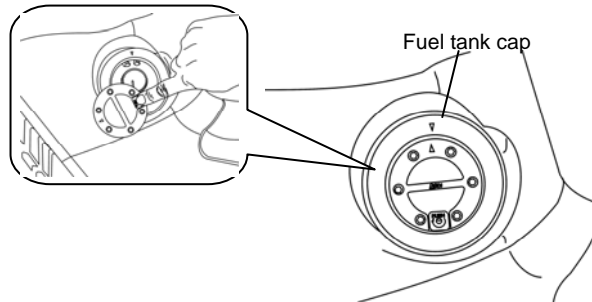

⚠ CAUTION:

- Main stand should be put down on the ground, engine should be shut off and flames should be strictly prohibited to ensure safety when refueling.
- Do not fill above fuel upper limit when refueling. Otherwise, fuel will flow out through a hole on the cap that may damage the body's painting, in serious cases, it may cause a fire to burn down the scooter.
- Make sure the cap has been tighten properly.

CUP FRAME

The cup holder is located in the center of floor panel.

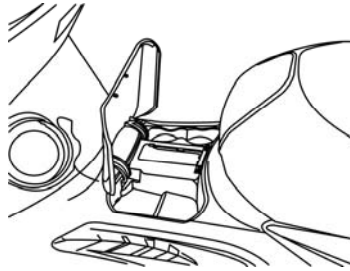

7. USE OF EACH COMPONENT

BRAKE

- Avoid unnecessary sudden braking.
- Use front and rear wheel brakes simultaneously when braking.
- Avoid brake continuously for a long period of time because that may overheat the brakes and reduce its braking efficiency.
- Slow down and brake early when riding in rainy days on slippery roads. Never apply the brakes suddenly to prevent skidding and falling.
- Using only the front brake increases the risk of falling because the scooter is tend to pulled to one side.

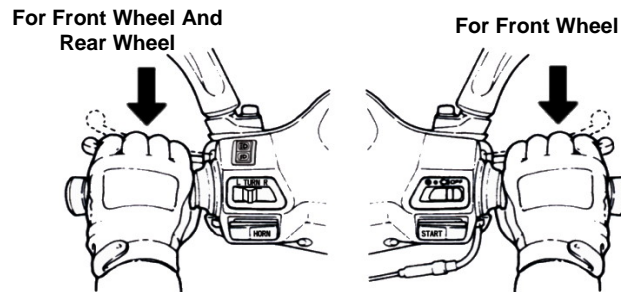

《Engine Brake》

Return the throttle valve handle back to its original position, and apply engine brake.

It is necessary to apply both brake and engine brake intermittently when riding on a long or stiff slope.

8. IMPORTANT POINTS AND CAUTIONS FOR STARTING ENGINE

CAUTION:

- Please check the engine oil and fuel volume are adequate or not before starting engine.
- To start engine the main parking stand must be firmly on the ground and the brake is applied on the rear wheel to prevent the scooter from moving forward suddenly.

Turn ignition switch key to the "ON" position.

1. Apply rear wheel brake.
2. Do not accelerate, press starter button when the brake is applied.

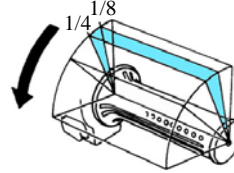
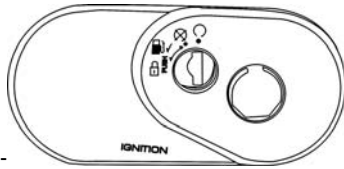

[We care for you! Before drive off, keep the hand brake applied on the rear wheel.]

CAUTION:

- If engine can not be started after starter motor running for 3~5 seconds, turn the throttle valve handle 1/8~1/4 turns, and then press starter button again for an ease start.
- In order to avoid damaging the starter motor, please do not press the starter button continuously over 15 seconds.
- If engine still can not be started after pressing starter button over 15 seconds, stop and wait for 10 seconds before start it again.
- It is harder to get the engine started after the scooter has been left idle for a long time or after refueling only after the fuel has been depleted. Then, it is necessary to press starting lever or starter button several times, and keep the throttle valve handle at the close position to start the engine.
- It may need several minutes to warm up engine if it is a cold start.
- Exhaust contains harmful gases (CO), therefore please start the engine at a well ventilated place.

[When starting engine with starting lever] (For HNA · HTA only)

- After step 1 is completed, press the starting lever forcefully by foot with the throttle valve handle at the close position.
- If engine is difficult to start with the starting lever when the engine is cold, rotating the throttle valve 1/8~1/4 turns will make the start easier.
- Put the starting lever back to its original position after the engine has been started.

CAUTION:

- Firmly support the scooter with the main parking stand before starting the engine with the starting lever.
- Start engine with the starting lever occasionally to prevent it from losing its function because of unused for a long time.

9. THE BEST WAY TO DRIVE OFF

- Turn on the turn signal light before moving, and make sure no vehicle is coming from behind. Then, drive off.

THE CONTROL OF THROTTLE VALVE HANDLE

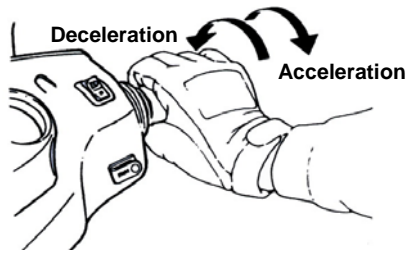

Acceleration : To increase speed. When riding on an inclined road, turn the throttle valve handle slowly to allow the engine to output its power.

Deceleration : To decrease speed.

PARKING METHOD

- When approaching the parking lot:
 1. Turn on the turn signal light early, and pay attention to the vehicles in front, from rear, left and right, then take the inner lane and approach slowly.
 2. Return the throttle valve handle back to its original position, and apply brakes in advance. (Brake light comes on when braking to warn drivers of vehicles behind.)
- When stop completely:
 3. Press the turn signal switch back to its original position, and turn the ignition switch key to "OFF" position to shut off the engine.
 4. Get off the scooter from left side after the engine has been stopped, and select a parking place where the scooter will not interfere with traffic and the ground is level, then put down scooter's main parking stand.
 5. Hold the steering handle with your left hand, and hold down the front end of saddle or hold the parking handle on the lower-left side of saddle with your right hand.
 6. Press the main parking stand with your right foot, put down the main parking stand firmly on the ground.

To remind you: Lock the steering handle and remove the key after parking to prevent the scooter from being stolen.

 **CAUTION:**

- Park your scooter at a safe place where it will not interfere with traffic.

10. INSPECTION AND MAINTENANCE BEFORE RIDING

(Please refer to the components location diagram for the following components.)

ROUTINE INSPECTION

Check Items		Check Key Points
Engine Oil		Is there enough engine oil?
Fuel		Is it enough? Is it Octane 90 or above
Brake	Front	Braking condition? (Brake lever free play: 10~20mm)
	Rear	Braking condition? (Brake lever free play: 10~20mm)
tires	Front	Is tire pressure normal? (Standard: 1.5kg/cm ²)
	Rear	Is tire pressure normal? (Standard: 2.25 kg/cm ² for 1 person, 2.5 kg/cm ² for 2 persons)
Steering Handle		Does the handle vibrate abnormally or is difficult to turn?
Speedometer, lights, and rearview mirror		Is it operated properly? Do lights come on? Can it be seen clearly from behind?
Tightness of Main Components		Are screws, nuts loosen?
Abnormal Points		Do the previous troubles still exist?



CAUTION:

- If any problem founded during routine inspection, correct the problem before using the scooter again, have your scooter checked and repaired by the "SYM dealer or authorized service personnel" if necessary.

ENGINE OIL INSPECTION AND CHANGE

INSPECTION:

1. Use the main parking stand to support the scooter on a level ground, remove the dipstick after engine stopped for 3~5 minutes. Wipe oil off the dipstick and then insert it into the guide tube again (Do not rotate it.)
2. Remove the dipstick and check whether oil level is in between the upper and lower marks.

Add oil to upper limit if oil is under the lower limit. (Check cylinder, crankcase...etc for leakage.)

OIL CHANGE:

- Change engine oil after the first 300km, and change the engine oil every 1000km thereafter. Clean oil filter after the first 300km, and clean oil filter every 6,000km.
- In order to maintain the engine's maximum performance, check whether the engine oil is enough every 500km. Add oil to upper limit if the engine oil has been found to be inadequate.
- Engine Oil : Use API SH, SAE 10w-30 grade or better engine oil. Otherwise, damage will not be covered by warranty.
- ※ Recommended Oil: **SYM Genuine EXTRA 4X OIL.**
- Oil Capacity :
 - GTS 250 : 1.4 Liter (1.2 liters for routine change),
oil filter change: 1.2 liters.
 - GTS 200/125 : 1.0 Liter (0.8 liters for routine change),
oil filter change: 0.8 liters.

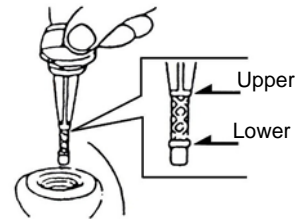

10. INSPECTION AND MAINTENANCE BEFORE RIDING

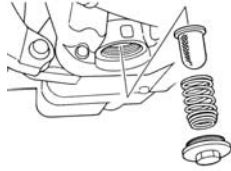

【Oil Filter Cleaning】

Open the filter nut assembly of the element, and remove the element. Remove the foreign materials from the element by using a gasoline or air spraying gun.

WARNING:

- Oil level will not be correct when checking the oil level with the scooter parked on an unlevelled ground or immediately after the engine stopped.
- Engine and exhaust pipe are hot right after engine stopped. Pay special attention not to get burned when checking or replacing engine oil.

FUEL INSPECTION

- Turn main switch key to "ON" position, and check fuel gauge's needle range to make sure there is enough amount of fuel in the fuel tank.
- This scooter's engine is designed for using the unleaded fuel of Octane 90 or above.
- Firmly secure the main stand on the ground, shut off the engine and keep flames away from the scooter when refueling.
- Do not fill above fuel upper limit level when refueling.
- Make sure the fuel tank cap had been tighten properly.

TRANSMISSION OIL INSPECTION AND CHANGE

INSPECTION:

- Use the main stand to support the scooter on a level ground, after the engine stops, wait for 3~5 minutes. Remove the transmission oil infusion bolt, put a measuring glass under the drain bolt, and remove the drain bolt. Let the oil flows into measuring glass and check for decreased or not.

(GTS 250 : at disassembly: 180 c.c. / at change: 170 c.c.)

(GTS 200 / 125 : at disassembly: 110 c.c. / at change: 100 c.c.)

OIL REPLACEMENT:

- Stop the engine and use the main stand to support your scooter on a level ground. Remove the infusion bolt and drain bolt, drain out the oil.
 - Install the drain bolt and tighten it. Fill new transmission oil (170 c.c./ 100 c.c), and install the infusion bolt and tighten it. (make sure that bolts are tightened and check that there's no leakage.)
- ※ Recommend Oil: Genuine SYM HYPOID GEAR OIL (SAE 85W-140).

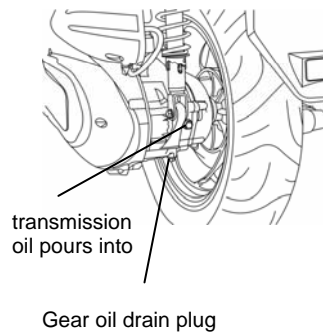

10. INSPECTION AND MAINTENANCE BEFORE RIDING

INSPECTION AND ADJUSTMENT OF BRAKE FREE PLAY

INSPECTION: (Brake lever free play must be checked with the engine shut off.)

- Brake lever free play for front and rear wheels

When checking the hand-braking lever for front and rear wheels, its free play (the stroke of hand-braking lever from no braking to initial braking) should be 10~20mm. It is abnormal if the feel is spongy when holding the hand-braking lever forcefully.

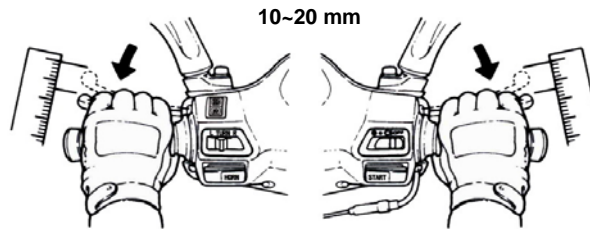

DISK BRAKE INSPECTION (Applicable for model equipped with disc brake.)

(Leak, damaged, looseness of brake line)

- Visual check brake lines for leakage, or damage, check brake lines connections for looseness using a wrench or similar tool, and check whether steering handle vibration in driving, or any parts' interference may have damage the brake lines. If so, bring your scooter to your SANYANG dealer for repairing or service.

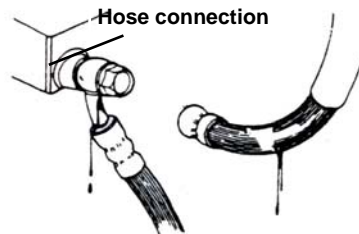

CAUTION:

- Please drive your scooter on a dry road surface slowly and operate front and rear brakes in order to find out if there is any malfunction so as to ensure the scooter is at its optimum condition and safe to ride.

10. INSPECTION AND MAINTENANCE BEFORE RIDING

(Checking front brake lining)

- Check the brake from behind the brake caliper. The brake pad must be replaced with new lining when the brake pad wear limit reaches the brake disk.

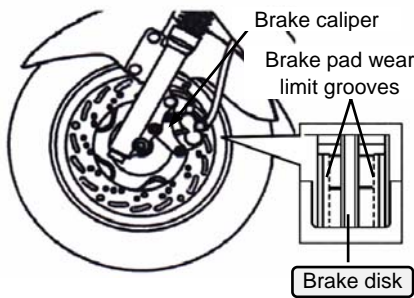

(Checking oil quantity in brake oil reservoir)

- Park the scooter on a level ground, and check if fluid level is under the "LOWER" mark. Recommended Brake Fluid: WELL RUN BRAKE OIL (DOT 3).

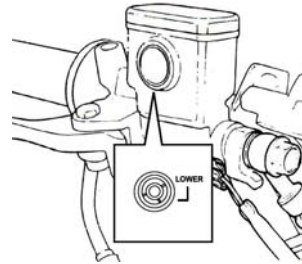

(Replenishment of front wheel brake fluid)

1. Loosen the screws and remove the master cylinder cover.
2. Wipe clean foreign materials, dirt around the reservoir, being careful not to let foreign materials fall into the reservoir.
3. Remove the diaphragm plate and the diaphragm.
4. Add brake fluid to upper level.
5. Install the diaphragm plate and the diaphragm, and install the master cylinder cover.
6. Please note the diaphragm direction, and do not let foreign materials fall into the reservoir. And tighten the master cylinder cover securely.

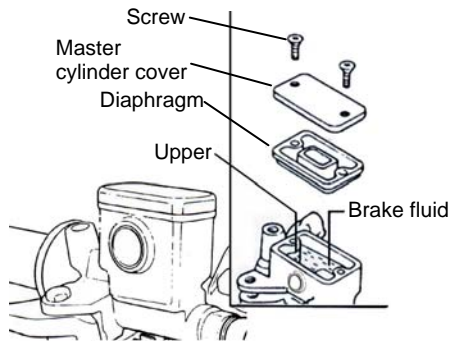

CAUTION:

- To prevent chemical reaction, please do not use brake fluids other than those recommended.
- Do not fill above the upper limit when adding brake fluid and avoid dropping on painting or plastic components to prevent damage.

THROTTLE VALVE HANDLE CLEARANCE ADJUSTMENT

- Correct clearance allows throttle valve handle to rotate 2~6mm.
- Loosen the lock nut first, then turn the adjust nut to adjust. Tighten the lock nut securely when finished.

Check Items:

1. Check throttle valve cable to see if it can be moved smoothly from a closed position to a wide open position.
2. Rotate steering handle from side to side to check if the throttle valve cable is interfered.
3. Check to see if the throttle valve cable is obstructed by other cables preventing it from being operated smoothly.

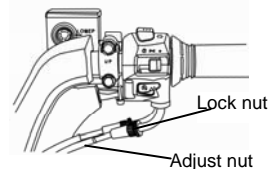
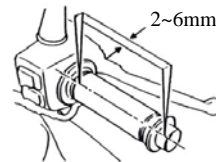

10. INSPECTION AND MAINTENANCE BEFORE RIDING

INSPECTION AND MAINTENANCE OF BATTERY

- This scooter is equipped with a maintenance-free type battery, so it is unnecessary to check and add electrolyte. Have your scooter checked by SYM Authorized Dealer or Franchised Dealer should any abnormality is found.

〈 Cleaning of battery terminals 〉

Remove the battery terminals and clean if there are dirt and corrosion on them.

Battery removal procedures are as follows:

Turn ignition switch "OFF", then open the battery cabinet door, and remove negative cable screw firstly and disconnect the negative cable. Then, remove positive cable screw and positive cable.

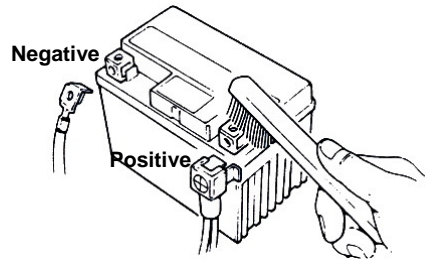

⚠ CAUTION:

- Clean the battery posts with warm water if the posts are eroded and have some white powders on them.
- If there is an obvious erosion on the terminals, disconnect the cables, then clean the erosion off with a steel brush or a piece of sandpaper.
- Install battery cable after cleaning and apply a thin coat of grease on the terminals.
- Install battery in reverse order of removal.

- This scooter is equipped with a maintenance-free type battery, so it is unnecessary to check and add electrolyte. Have your scooter checked by SYM Authorized Dealer or Franchised Dealer should any abnormality is found.

⚠ CAUTION:

- This is a closed type battery. Never remove the caps.
- In order to prevent electric leakage and self-discharge when the battery sits idle for long periods. Remove battery from scooter, store it in a well-ventilated and dimly lighted place after the battery has been fully charged. Disconnect battery's negative cable if the battery is still kept on the scooter.
- If the battery needs to be replaced, replace with a same closed-type battery (Maintenance-Free).

10. INSPECTION AND MAINTENANCE BEFORE RIDING

TIRE INSPECTION

- Tires should be checked and inflated with the engine shut off.
- If a tire's ground contacting curve is abnormal, check it with an air pressure gauge and inflate it to the specified pressure.
- Tires pressure must be checked with an air pressure gauge when cold.

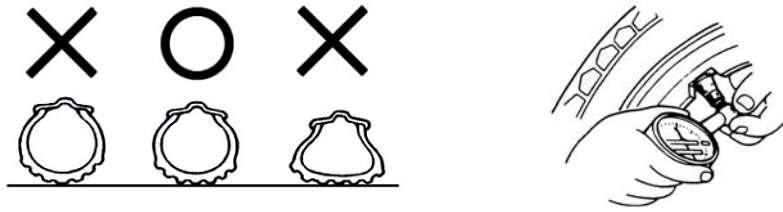

PLEASE REFER TO SPECIFICATIONS FOR STANDARD TIRE PRESSURE

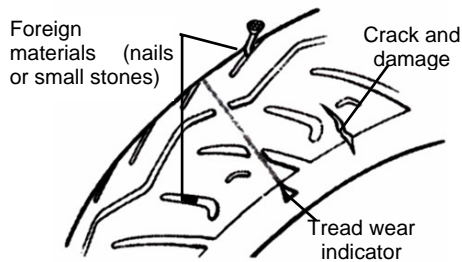

- Visual check tires for frontal and lateral side walls for crack or damage.
- Visual check tires for any nails or small stones wedged in the tread.
- Check the "tread wear indicator" condition to see if tread groove depth is insufficient.
- A tire with a wear bar showing is worn out and should be replaced immediately.



CAUTION:

- Abnormal tire pressure, wear, or crack is the most important cause that results in the loss control of the steering handle and a punctured tire(s).

STEERING HANDLE FRONT SHOCK ABSORBERS INSPECTION

- Perform this check with engine shut off and ignition switch key removed.
- Visual check front shock absorbers for damage.
- Operate steering handle up and down, and check front shock absorbers for noises due to bends.
- Check the bolts and nuts of front shock absorbers with wrenches for tightness.
- Shake steering handle up & down, left & right, and front & rear to check if it is loosen, has too much resistance and pulls to one side.
- Check steering handle if it is being pulled too tight by the brake cables.
- Take your scooter to SYM Authorized Dealer or Franchised Dealer for a check or adjustment if any abnormal conditions are found.

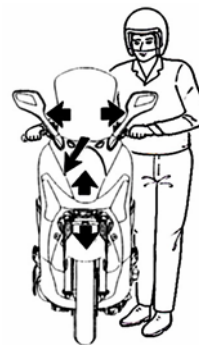

10. INSPECTION AND MAINTENANCE BEFORE RIDING

REAR CUSHION HARDNESS SETTING

The rear cushion is 5 stage adjustable type. It's set at 3th stage when manufactured, and you can adjust it depending on your need. Turn the adjust collar of the cushion to adjust it's hardness.



CAUTION:

- Turn counterclockwise to harden it, and turn clockwise to soften it.
- Mark sure adjust both cushion at the same time to be sure the riding stability.

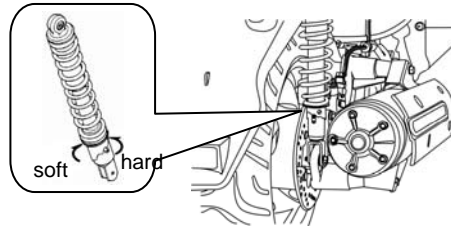

CHECKING AND CHANGING FUSES

Turn off ignition switch, and check fuses if they are intact. Replace the blown fuse with a new one having the same specified amperage rating (20A). Using a fuse of more than 20 amperes, a brass or iron wire to replace a blown fuse is strictly prohibited to avoid damaging the electrical system and the circuit.

- Remove the storage box, and you'll find the fuse box near light.
- Open the fuse box cover, and pull out the fuse. Check it for damage or broken.
- Fuses must be firmly secured with wire connectors when replacing. Loose connections will result in overhead and damage.
- Use only parts having the specified specification to replace electrical components such as light bulbs. Using parts not having the specified specifications for replacement may cause the fuse to blow and over-discharge the battery.
- Avoid spraying water directly on or around fuse box when washing the scooter.
- Take your scooter to your dealer for an inspection if a fuse is blown by unknown causes.

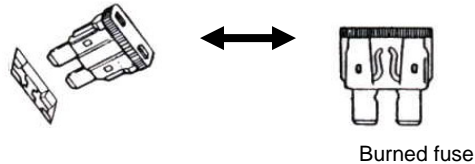
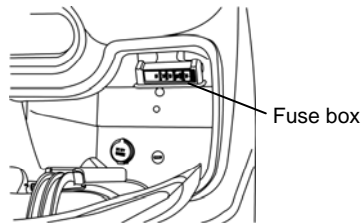

CHECKING THE TURN SIGNAL LIGHTS AND HORN

- Turn the ignition switch key to "ON" position.
- Turn on the turn signal light switch, and make sure that the front & rear and left & right signal lights flashes and also check if the warning buzzer sounds.
- Check turn signal light covers if they are dirty, crack, or loosen.
- Press horn button to check if it works.



CAUTION:

- Specified specification bulbs should be used for turn signal lights. Otherwise, the normal operation of turn signal lights will be affected.
- Turn on the turn signal light before turning or switching lane to warn driver of vehicles behind.
- Turn off the turn signal light immediately by pressing its button down after using. Otherwise, the flashing of twin signal lights may confuse the drivers of vehicles behind.

10. INSPECTION AND MAINTENANCE BEFORE RIDING

CHECKING THE FRONT AND REAR LIGHTS

- Start engine and turn on the head lamp switch. Check if head lamp and rear lamp come on.
- Check the brightness and direction of front light by wall to see if it is correct.
- Check the head lamp cover if it is dirty, crack, or loosen.

CHECKING THE BRAKE LIGHT

- Turn the ignition switch key to "ON" position, hold the hand-braking levers for front and rear wheels. Check if the brake lights come on.
- Check the brake light cover if it is dirty, crack, or loosen.



CAUTION:

- Use only specified specification bulbs, do not use bulbs with different specifications to avoid damaging electrical system, burning out bulbs, and discharging the battery.
- Do not modify or add other electrical components to prevent over load or short circuit which may result in a fire and burn down the scooter in serious cases.

CHECKING FOR FUEL LEAKAGE

- Check fuel tank, fuel cup, fuel hoses, carburetor for leakage.

CHECKING THE LUBRICATION OF BODY'S VARIOUS MECHANISMS

- Check the body's pivot points if they have enough lubrication.
(For example, the pivot points on the main stand, the side stand, and the brake lever...etc.)

CHECKING THE SPARK PLUG

- Remove the cap of spark plug cable (remove the spark plug using the spark plug wrench in the tool kit).
- Check the electrode if it is dirty or fouled by carbon deposits.
- Remove the carbon deposits on the electrode with steel wire, and clean the spark plug with gasoline, then, wipe dry with a rag.
- Check the electrode, and adjust its gap to 0.8 mm. (Check it with a feeler gauge)
- Hand tight the spark plug as far as it can go and then tighten it another 1/2~3/4 turns with a wrench.

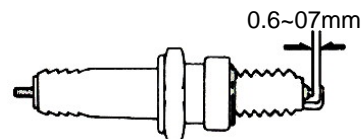
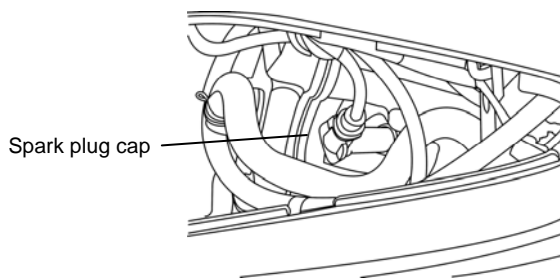

WARNING:

- The engine is very hot after running. Pay attention not to get burned.
- Use only spark plugs suitable for the engine specifications of this scooter recommended by the manufacturer. (Refer to specifications.)

10. INSPECTION AND MAINTENANCE BEFORE RIDING

COOLING SYSTEM INSPECTION

(Checking coolant level)

1. Support vehicle with main stand on a level ground.
2. Check reserved tank from viewing window to see if coolant level is between the upper limit and lower limit mark.
3. Add coolant up to upper mark if coolant is close to the lower mark.

(Check the cooling system for leakage)

- Check radiator and piping for leakage.
- Check the ground where the vehicle is parked for water dripped from the vehicle.

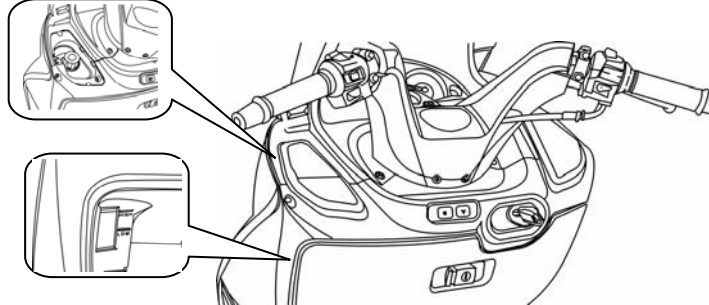

REPLENISHMENT OF COOLANT

Always keep radiator cap tightly closed.

1. Support vehicle on a level ground in a straight up position.
2. Open the battery cabinet door.
3. Open surge tank cap, refill coolant until reaches the upper mark.

- If coolant level becomes too low and occurs too often, it may indicate there is something wrong with the coolant system.

- To avoid radiator getting rusty, do not use coolants other than those recommended.

Coolant recommended: SYM Bramax radiator agent

Concentration: 50%

Radiator capacity: Main radiator : 780 c.c.

Surge tank : 420 c.c.

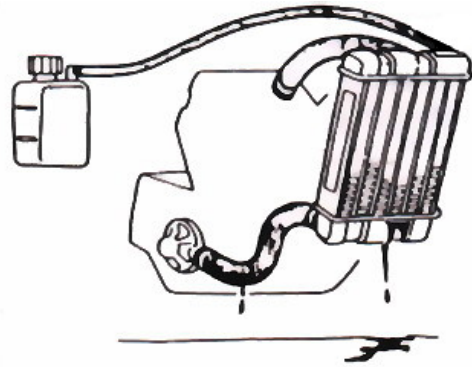

10. INSPECTION AND MAINTENANCE BEFORE RIDING



CAUTION:

- Use soft water when mixing coolant.
- Please pay special attention that using poor quality coolant may shorten the service life of the radiator.
- Coolant should be changed once a year normally.



CAUTION:

Please refer to a table showing what percentage of anti-freeze should be used under different temperatures if the vehicle is to be operated in the low temperature areas. (below 0°C)

A reference table for anti-freeze concentration percentages under different temperatures

1. Radiator anti-freeze specification for this scooter is H68. (SYM Bramax radiator agent)
2. Proper anti-freeze percentages for different frozen temperatures are as follows:

Anti-freeze percentage	Frozen temperature	Remark
20%	-8	50% concentration is used for all scooters before delivery to ensure the effectiveness of anti-freeze.
30%	-15	
40%	-24	
50%	-36	

3. If the specified anti-freeze is unavailable, use an equivalent with the same high quality.
4. Increase radiator maintenance intervals when the weather is extremely cold.

CRANKCASE BLOW-BY VENTILATION

Pull out the plug from draining hose to clean deposits



CAUTION:

- When always riding in rainy area or full throttle position, maintenance travel must be shorted. The deposits can be seen in the transparent section of draining hose.

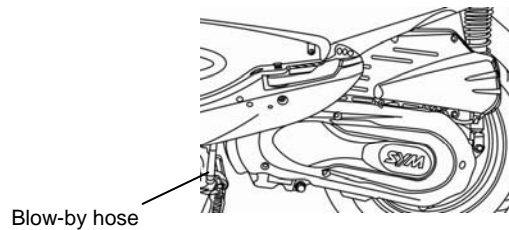

10. INSPECTION AND MAINTENANCE BEFORE RIDING

CHECKING THE AIR CLEANER

《DISASSEMBLE PROCEDURE》

1. Remove mounting screws from air cleaner cover.
2. Remove the air cleaner cover, then remove filter element.
3. Take the element out and clean it. (Refer to maintenance schedule.)

《ASSEMBLE PROCEDURE》

- Assemble the air cleaner in reverse order of disassemble.

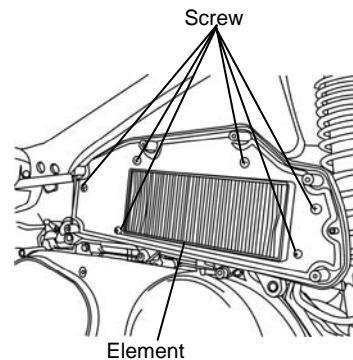
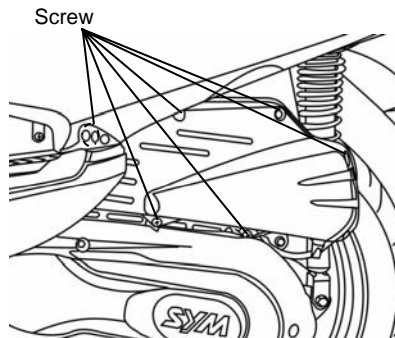

CHECKING THE LEFT CRANKCASE COVER AIR CLEANER

《DISASSEMBLE PROCEDURE》

1. Remove mounting screws from left crankcase cover.
2. Remove the left crankcase cover, then remove filter element.
3. Take the element out and clean it. (Refer to maintenance schedule.)

《ASSEMBLE PROCEDURE》

- Assemble the air cleaner in reverse order of disassemble.

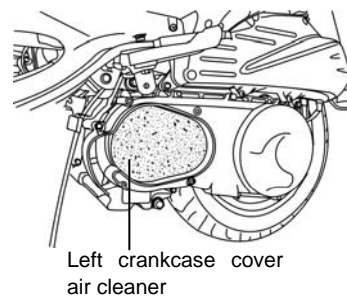
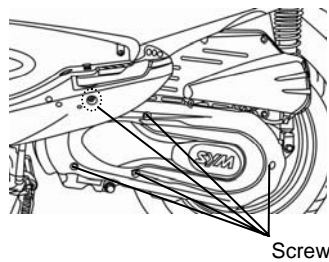

CAUTION:

- Dust deposit is one of the major causes of reducing output horsepower and increasing fuel consumption.
- Change the air cleaner element more frequently to prolong the engine's service life if the scooter is driven on dusty roads very often.
- If air cleaner is installed improperly, dust will be absorbed into cylinders, which may cause a premature wear and reducing output power and engine life.
- Be careful not to soak the air cleaner when washing the scooter. Otherwise, it will cause engine hard to start.

11. WHEN THERE IS AN ABNORMAL CONDITION OR A TROUBLE

DIAGNOSIS WHEN ENGINE DOES NOT START

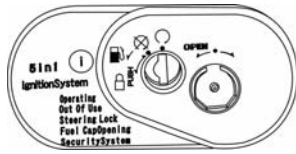

For Rear Wheel For Front Wheel

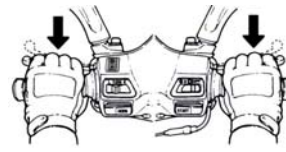

(1). Has the ignition switch key been turned to "ON" position?

(2). Is there enough fuel in the fuel tank?

(3). Is the rear or front wheel brakes applied when pressing starting button?

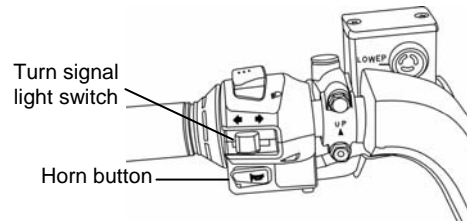
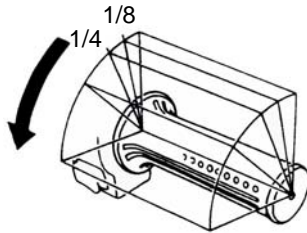

(4). Do you rotate the throttle valve handle while pressing starting the button?

(5). Turn the ignition switch key "ON", and press horn button down, if the horn does not sound, the fuse may have been blown.

[Have your scooter checked by SYM authorized dealer or franchised dealer immediately if there are no problems with the above items and engine still can not be started.]

12. C.D.I. ELECTRICAL IGNITION SYSTEM

The charge and discharge principle of a condenser is adopted for the C.D.I system to supply electrical energy created by generator's coil, to the ignition coil in accordance with specified ignition timing so that the spark plug may generate sparks as required.

13. SUGGESTIONS ON ENGINE FUEL

- This scooter is designed to use UNLEADED gasoline of Octane No. 90 or higher.
- If the scooter is operated in high altitude (where the atmosphere pressure is lower), it is suggested that the air/fuel ratio should be readjusted to maximize the engine performance.

14. TRANSMISSION OIL

- Recommended Oil: Genuine SYM HYPOID GEAR OIL (SAE 85W-140)

15. CAUTIONS FOR RIDING SCOOTER

1. Raise the scooter with the main stand, and sit on the saddle.

Push the scooter forwarding to raise the main parking stand.



CAUTION:

- Never rotate the throttle valve handle at will to increase the engine RPM before driving off.

2. Get on the scooter from the left side, and sit on the saddle properly, keep your feet firmly on the ground to prevent the scooter from falling.



CAUTION:

- Apply brake on the rear wheel before driving off.

3. Rotate the throttle valve handle slowly, and then the scooter will begin to move.



CAUTION:

- Rapidly rotate the throttle valve handle may cause the scooter moving forward suddenly and it is very dangerous.
- Make sure the side parking stand is spring back completely before driving off.

【Do not use the brake suddenly and make a sharp turn】

- Rapid braking and sharp turning will cause slip and fall.
- Rapid braking or sharp turning will cause slipping, lateral slipping, or fall especially in rainy days when the road is wet and slippery.

【Drive with extreme caution during rainy days】

- The brake distance in rain day or on wet road will longer than that on a dry road. Therefore, slow down and prepare to apply the brake earlier.
- The throttle valve handle should be released, and the brakes should be properly applied as it is needed while reducing the speed when going down a slope.

16. PERIODICAL MAINTENANCE SCHEDULE

Item	Maintenance kilometer	300KM	Every 1,000KM	Every 3,000KM	Every 6,000KM	Every 12,000KM	Remarks
	Check Items	Maintenance Interval	NEW	1 Month	3 Months	6 Months	
1	Air cleaner element(Remark)	I		C	R		
2	Oil filter(Screen)	C			C		
3	Engine oil	R	I	Replacement for every 3,000KM			
4	Tire, pressure	I	I				
5	Battery	I	I				
6	Spark plug	I		I		R	
7	Carburetor(idle speed)	I			I		
8	Steering bearing and handles	I		I			
9	Check Transmission for leakage	I	I				
10	Check crankcase for leakage	I	I				
11	Transmission Oil	R	Replacement for every 5,000KM (5 Months)				
12	Drive Belt/roller				I	R	
13	Fuel tank switch and lines	I		I			
14	Throttle valve operation and cable	I	I				
15	Engine bolts and nuts	I		I			
16	Cylinder head, cylinder, and piston				I		
17	Exhaust system/cleaning carbon				I		
18	Cam Chain/ignition time	I		I			
19	Valve clearance	I			I		
20	Shock absorbers	I			I		
21	Front/rear suspension	I			I		
22	Main/side stands	I			I/L		
23	Crankcase Blow-by system(PCV)	I		I			
24	Coolant	I	I			R	
25	Cooling fan, lines	I	I				
26	Clutch disk				I		
27	Brake mechanism/brake lining (pad)	I	I				
28	Bolts/nuts for each components	I	I				

☆The above maintenance schedule is established by taking the monthly 1000 kilometers as a reference which ever comes first.

※Have your scooter checked and adjusted periodically by your SYM Authorized Dealer or Franchised Dealer to maintain the scooter at the optimum condition.

Code: I ~ Inspection, cleaning, and adjustment R ~ Replacement
C ~ Cleaning (replaced if necessary) L ~ Lubrication

Remark: 1. Clean or replace the air cleaner element more often when the scooter is operated on dusty roads or in the Heavily- polluted environment.
2. Maintenance should be performed more often if the scooter is frequently operated in high speed and after the scooter has accumulated a higher mileage.

【Notes in the remarks are used to indicate the applicable models.】

17. SPECIFICATION

Model	GTS 250	GTS 200	GTS 125
Item	Specification	LM25W	LM18W
length		2,165 mm	
width		870 mm	
Height		1,380 mm	
Wheel base	1,495 mm	1,475 mm	
Net Weight	173 kg	165 kg	163 kg
Type	4- stroke 4V electroplated ceramic cylinders engine		
Fuel	UNLEADED(OCTANE 92 OR HIGHER)		
Cooling type	Water-cooled		
Displacement	250.6 cc	171.2cc	124.5cc
Compression ratio	10.5:1	10:1	10.5:1
Max. HP	21 ps / 7,500 rpm	14.5 ps / 8,000 rpm	11.4 ps / 8,500 rpm
Max. torque	2.2 kgf-m / 6,500 rpm	1.4 kgf-m / 6,500 rpm	1.01 kgf-m / 7,000 rpm
Starting methods	Electrical & foot type		
Front shock absorber	TELESCOPE		
Rear shock absorber	UNIT SWING		
Clutch	Centrifugal type		
Transmission	CVT		
Front tire	110 / 90-13 56P		
Rear tire	130 / 70-13 57P	130 / 70-12 64P	
Wheel	Aluminum alloy		
Tire pressure	Front: STD 1.5kg/cm ² , Rear: STD 2.25 kg/cm ² for 1 person, 2.5 kg/cm ² for 2 person		
Front brake	Disc type (Ø 240 mm)		
Rear brake	Disk type (Ø 220mm)		
Front light bulb(high, low)	12V 55W / 55W		
Brake light bulb(tail light)	LED		
License light bulb	LED		
Turn signal light bulb	12V 21Wx4		
Engine oil capacity	1.4 L (1.2 L for change)	1.0 L (0.8 L for change)	
Transmission oil capacity	180 cc. (170 cc. for change)	110 cc. (100 cc. for change)	
Fuel tank capacity	12 L	8.5 L	
Fuse	20Ax3, 15Ax2		
Spark plug	NGK CR 8E		
Battery capacity	YTX12-BS	YTX9-BS	
Air cleaner	Paper type		
Fuel tank cap	Open lock type		
Front light	General type (single)		
Rear grab frame	Can not load cargo		

SYMEN 2005/05